



VP-200 Ground Parallels

ORDER NO.VP-200 CODE NO.1004-085



VERTEX

NEW



MADE OF HIGH GRADE
ALLOY STEEL
HARDENED AND
GROUND.
ACCURACY: 0.01/100 MM

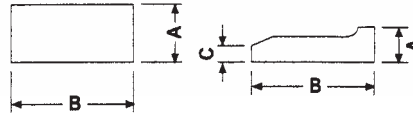

FOR OVER 150 m/m, 200m/m
JAW PLATE VISE USING

BODY SIZE	CLAMP SIZE
AxBxLxPcs	AxBxCxLxPcs
5x16x150x2	31x15x200x2x2.5
6x18x150x2	
8x24x150x2	
10x30x150x2	
12x36x200x2	
14x48x200x2	
18x60x200x2	
22x62x200x2	



Adjustable Angle Plate

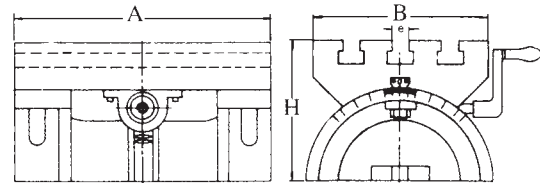

Unit:mm

ORDER NO.	TABLE LxW			T-SLOT	APPROX WEIGHT(kg)	CODE NO.
	A	B	H	e		
VP-180	180	130	91	10	7.4	1004-089
VP-250	255	181	133	12	28.7	1004-090
VP-380	380	254	185	16	56.3	1004-091
VP-600	600	300	205	16	85.3	1004-092

1. For angle setting on various machine tools.
2. Adjustable 45° each side.
3. Material: FC30
4. Lower plate and bigger working space.



Angle Plate With Swivel Base

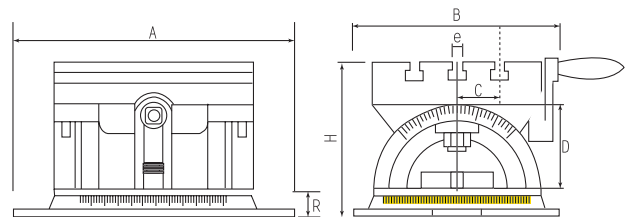
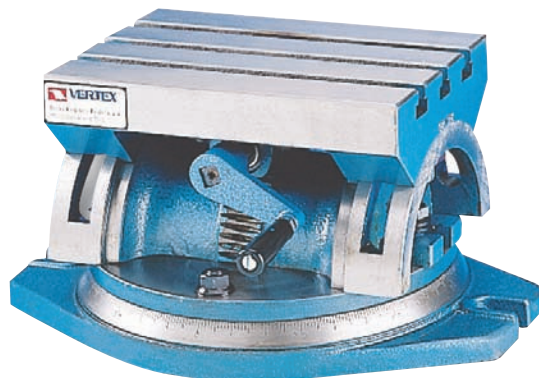

Unit:mm

ORDER NO.	Table LxW			T-SLOT			R	WEIGHT (kg)	CODE NO.
	A	B	H	e	C	D			
VP-250S	243	230	177	10	50	90	40	40	1004-100
VP-380S	360	270	233	12	68	127	48	76	1004-101

360° SWIVEL BASE.



VCT-407



VCT-514

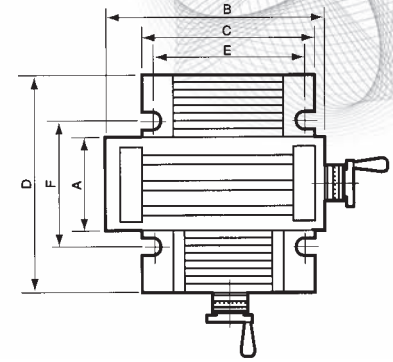

- Material: over FC-30
- Precision: 0.02/100mm
- Feature: The sliding surfaces are treated by heat-treatment & precision ground
- Can be used as measurement table

Specifications

Unit:mm

ORDER NO.	A	B	C	D	E	F	Stroke	T Slot	Total height	Dial graduation	PACKING LxWxH m/m	WEIGHT kgs	CODE NO.
VCT-407	100	180	130	100	115	50	50x80	3/8"	100	2.5mm/0.02	290x240x140	11.9	1007-001
VCT-514	150	350	250	300	206	208	156x170	3/8"	134	4mm/0.02	510x450x240	33.4	1007-002
VCT-820	200	500	300	400	250	290	200x250	3/8"	155	4mm/0.02	640x520x200	72	1007-003
VCT-1024	250	600	400	500	340	430	250x300	1/2"	210	4mm/0.02	790x680x310	141	1007-004



Precision Cross Table

ORDER NO.VCT-830 CODE NO.1007-010



VCT-830

A heavy, rugged slide in all kinds of positioning, milling, drilling micro-scope viewing and staging, adjustable bases for heavy loads, small jig boring, precision cut-off.

Specifications

Unit:mm

ORDER NO.	A	B	C	D	E	F	Stroke	T Slot	Total height	Dial graduation	PACKING LxWxH m/m	WEIGHT kgs	CODE NO.
VCT-830	210	730	345	410	310	230	190x350	16	185	2.5mm/0.05	991x584x292	99.9	1007-010



Cross Table

ORDER NO.VCT-512 CODE NO.1007-020



VCT-512

Table: 300x140mm
 Height: 115mm
 Travel: 200mm longitudinal.
 125mm transverse.
 Base: 225mm x 200mm oval with U slots for up to 16 bolts on 190 to 210 bolts circle.
 Dial Graduated: 0.03mm
 Net weight: 16.4kgs.
 Packing Volume of each unit: 430x265x155mm
 LIGHT DUTY ONLY